



Aastra 5000 Communication Systems

**Aastra 6757
Attendant
console**

User's Guide



Description of the terminal 1

Overview	1
Attendant console operating keys	3
Indicator lights associated with the keys	3
Interactive display	4
Using interactive keys	5
Alphanumeric keypad	6
Accessories	6

Call modes 7

Hands-free mode	7
Headset mode	8
Amplified listening mode	9
Predial mode	9
Adjusting the listening volume level	10
Calling a correspondent by name	10
Dialling a common abbreviated number	11

Using the attendant console 12

Activating / deactivating the attendant console	12
Answering calls	14
Making a call	18
During a call	21
Ending a call.	24

Attendant console services. 25

Reserving external lines	25
Programming and managing the system.	26
Using the hotel function	28
Displaying calls	32
Displaying trunk line statuses	32
Monitoring grouped lines	33
Notifying a correspondent	33

Contents

Programmable keys	35
Programming a key	35
Erasing, modifying, exiting programming	37
Identifying programmed keys	38
The supervision function	39
Programming the supervision function	39
Communicating with the supervision function	40
Multi-key function	41
Programming the multi-key function	41
The multi-line function	43
Programming the multi-line function	43
Communicating with the multi-line function when attendant console enabled mode	45
Communicating with the multi-line function in attendant console disabled mode	46
Set settings	48
Choosing and adjusting the terminal ring tone	48
Adjusting the screen contrast	49
Adjusting the volume level of the beeps heard when a key is pressed	50
Choosing the terminal language	50
Choosing how to be alerted to incoming calls	50
Programming automatic answer	51
Miscellaneous	52
Glossary (terms you need to know)	52
Troubleshooting Check...	53

Installing the terminal	54
Connections	54
Mounting the telephone	55
Installing module M670 on Aastra 6757	57
Programmable key equivalence	58
Tips and safety	59

Description of the terminal

Description of the terminal

Overview

Your Aastra 6757 terminal has been set to attendant mode. Thanks to the extension module, which has been added to it, you can use it as an attendant console with all the standard functions necessary for proper management of incoming and outgoing calls.

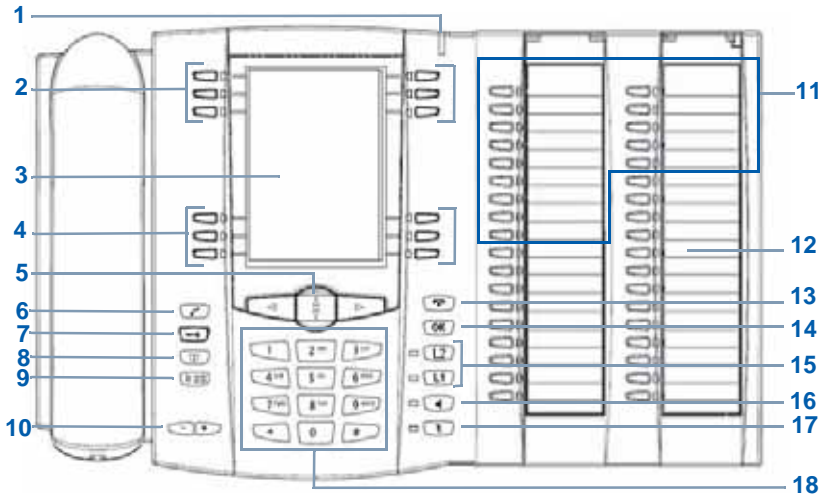

1 Message indicator





Indicates incoming calls

- 2** Keys not available when the terminal is used in attendant mode.

3 LCD screen

- 4 5 interactive keys** plus 1 key for direct access to call by name (ABC).











5 Navigator:

- You can use the  or  keys to display columns or sheets.
- You can use the  or  keys to display more information or make some adjustments.

- 6 Green key**, for redialling the last number dialed (Redial function), when the terminal is idle or busy



Description of the terminal

- 7 **Tools key**, for accessing:
- The ringer settings (ring tones and volume)
 - The screen contrast settings.
- 
- 8 **Directory key**: not active on the terminal when set to attendant mode.
- 
- 9 **R key (flashing)**:
Used during a call to dial another number (example: to call a second correspondent).
- 
- 10 **+ / - keys**:
- These keys have the same functions as the ◀ or ▶ keys on the navigator.
 - You can use them to adjust the call ringer.
- 
- 11 **Operating keys** described below.
- 
- 12 **Programmable keys**, with associated LEDs, whose descriptions have to be written on the labels.
- 
- 13 **Red key**, used:
- To end a call in progress
 - During programming, to cancel, set or end a programming sequence.
- 
- 14 **OK key**
For confirming an option, setting or input.
- 
- 15 **Programmable L1/L2 keys**, with associated LEDs:
These keys allow the same programming operations as the extension module keys but do not have any associated labels.
- 
- 16 **Loudspeaker key** used, during a call, to activate and deactivate amplified listening and handsfree modes.
The associated LED lights up or blinks as the case may be.
- 
- 17 **Secret key**, used during a call to:
- Mute the microphone (handset, handsfree function or headset with microphone) and hold a private conversation without being heard by the correspondent.
- The activated, associated LED reminds you about the activation.
- 
- 18 **Alphanumeric keypad**:
- For dialling some numbers or writing some texts.

Description of the terminal

Attendant console operating keys

The operating keys are located on the terminal extension. They are described below:

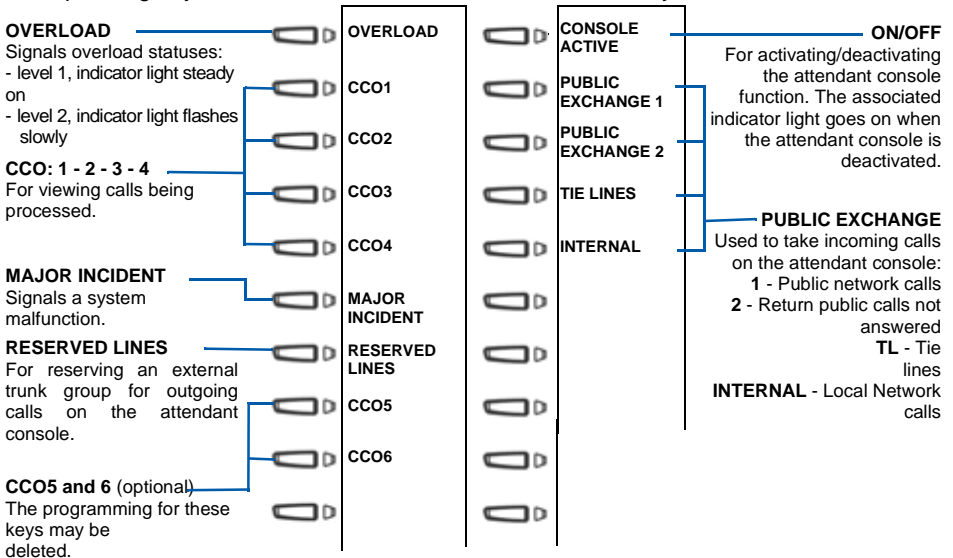

Indicator lights associated with the keys

Their four statuses indicate the status of the line or programmed function:

- Incoming call: indicator light blinks slowly
- Correspondent on hold: Indicator light blinks rapidly
- Terminal on line or function enabled: Indicator light steady on
- Line free/function disabled: Indicator light off.

Description of the terminal

Interactive display

The information provided by the display varies according to context, the programming of the terminal and associated system.

Idle: When the terminal is idle, the display shows the number of incoming calls for each arrival (1 - 2 - INTERNAL or TL):

PE2:00	PE1:00
INT:01	TL:00

During a call: The first line gives the identity of the correspondent engaged in an internal call:

CALL FROM
XXXX 000/000 ABO. XXXX

During an external call:

PUB.EXCHANGE:
XXXXXXXXXX EQ: 01/06/09

The functions accessible during a call are displayed with the interactive keys at the bottom of the screen.

During programming:

The display gives the label of the programming:

WHAT DO YOU WANT
TO PROGRAM?

The interactive keys at the bottom of the screen propose the functions accessible during programming.

Setting:

The display gives the label for the setting:

↓ RING

The user can use the navigator to access the columns, make the adjustments and then confirm.

Description of the terminal

Using interactive keys

The lower part of the display contains 6 interactive keys. Each interactive key corresponds to a function proposed on the display. Depending on the case, some interactive keys are not associated with any function.

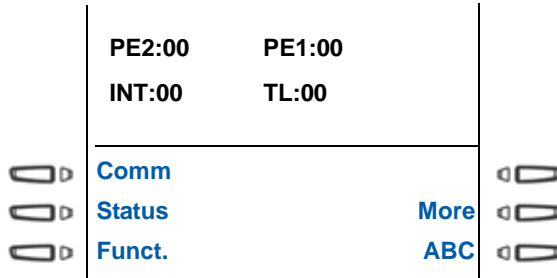

To access a function, press the interactive key associated with this function (**Comm** for example).

In some cases, the number of available functions may be more than five:

- To access the next functions, press the interactive key **-->** or **more**.
- To access the previous functions, press the interactive key **<--**.

You can use the interactive keys:

- **Previous** to return to the previous screen
- **Content** to return to idle mode.

Description of the terminal

Alphanumeric keypad

You can use the alphanumeric keypad to enter letters and figures. The input is based on key correspondence with letters or signs.

Text input lets you:

- Call by name a correspondent in the system directory
- Write a free message to alert a correspondent.

When a text input is proposed:

- Select the character you want by pressing the corresponding key successively.

Example:

- Pressing the key 2 once displays the letter A.
- Pressing the key 2 twice displays the letter B.
- Pressing the key 2 three times displays the letter C.
- Pressing the key 2 four times displays the figure 2.

You can use the key 1 to enter the following characters:

- During text input: - / space : . " , < > = + ? ! % 1
- In call by name mode: - . : 1

Note: in this mode, you can use the key 0 to enter: space and 0, and the key * to enter: ? ! # *.

Letters can only be entered in upper case.

During the input:

- To enter another letter located on another key:
-> Press this key without waiting then make a new input.
- To enter another letter located on the same key:
-> Wait for the cursor to blink on the next location to make the input.

To correct an input:

- 1 - Press the < or > key to select the character to replace (cursor placed under the character).
- 2 - Enter the new character.

In call by name mode, use the interactive keys dedicated to call by name (See "Calling a correspondent by name" on page 10.).

To confirm an input, press OK.

Accessories

Headset with microphone:

This terminal may be fitted with a headset with microphone. After connection, headset mode replaces handsfree mode.

Call modes

Your telephone proposes various call modes suited to your activities.

These features complete the standard handset mode (or discreet mode): lifting the handset to answer or make a call and replacing the handset to end a call.

Hands-free mode

Handsfree mode lets you make or answer a call without lifting the handset. You can switch from handsfree mode to handset mode and vice versa during a call.

Caution: when a headset is connected to the terminal, headset mode replaces handsfree mode.

Answering a call in handsfree mode



When an incoming call is presented:

- press the programmed key **PUBLIC EXCHANGE 1 - 2 - TL** or **INTERNAL** with a blinking indicator light (Incoming 1 for example).
- > Without lifting the handset, you can discuss directly in handsfree mode. The indicator light associated with the  key goes on.

Making a call in handsfree mode



- Dial your correspondent's number directly on the keypad.

-> The dialled number is displayed as it is entered. Your terminal is automatically in handsfree mode.
When your correspondent off-hooks, you can discuss in handsfree mode.

Ending a call



- Press .

-> The line becomes free. The call is ended and the indicator light associated with the  key goes off.

Switching from handsfree mode to handset mode





You are discussing in handsfree mode:

- Just pick up the handset.
- > The conversation continues in handset mode (or discreet mode).
The indicator light associated with the  key goes off. At the end of the call, you must on-hook the handset.

Call modes

Switching from handset mode to hands-free mode

-   You are discussing in handset mode:
- Replace the handset.
- > The conversation continues in handsfree mode. The  key indicator light goes steady on.

At the end of the conversation, press the  key.

Headset mode



When a headset is connected to the terminal, headset mode replaces handsfree mode.

Answering a call in headset mode

-  **PUBLIC EXCHANGE 1**
- Your terminal is fitted with a headset with microphone. To be able to answer a call, the handset must be replaced.
- When an incoming call is presented:
- press the programmed key **PUBLIC EXCHANGE 1 - 2 - TL** or **INTERNAL** with a blinking indicator light (PUBLIC EXCHANGE 1 for example).
- You can discuss in headset mode.

-> The indicator light associated with the  key goes on.



Switching from headset mode to hands-free mode

-  
- You are discussing in headset mode:
- Press the loudspeaker key.
- > The conversation continues in handsfree mode.

Switching from headset mode to supervision mode

- 
- You are discussing in headset mode:
- Another person may lift the handset to monitor the call. The handset may be replaced at any time.
- > The conversation continues in headset mode.

Ending a call

- 
- Press .
- > The line becomes free. The call is ended and the indicator light associated with the  key goes off.

Calling a party



- Dial your correspondent's number directly on the keypad.

-> The dialled number is displayed as it is entered.

When your correspondent off-hooks, you can discuss in headset mode.

Amplified listening mode

Amplified listening mode is used, while the handset is lifted, to listen to a party on the loudspeaker so that other people can take part in the conversation.



During the call:

- Press the loudspeaker key.
- > Amplified listening is activated. The indicator light for the loudspeaker key goes steady on.

Note: You may continue to use the handset.



Disabling amplified listening:

- Press the loudspeaker key.
- > Amplified listening is disabled. The loudspeaker indicator light goes off.

Predial mode

Predial mode lets you dial and view a number in order to possibly make some corrections during input (this mode may be interesting while dialling long numbers, such as international numbers).

Comm

1 - Press the interactive **Comm** key.

Prenum

2 - Then press the interactive **Prenum** key.



3 - Dial the party's number.

-> The dialled number is displayed as it is entered.

Erase

In case of error, press the interactive **Erase** key then dial the number again.

Call

4 - Press the interactive **Call** key to start the call.

When the correspondent off-hooks, you can discuss in handsfree mode or headset mode or pick up the handset.

Call modes

Adjusting the listening volume level

No matter the mode used (handset mode, handsfree mode, headset or amplified listening mode), the listening volume is adjustable (8 levels). The setting is memorised.



or



To reduce the volume:

- Press the - key or the left navigator key.



or



To increase the volume:

- Press the + key or the right navigator key.

Calling a correspondent by name

The ABC key lets you search for a correspondent by name in the system directory.

Attendant console active or idle:

ABC



1 - Press the interactive **ABC** key.

2. Using the alphanumeric keypad, enter the first letters of the name of the correspondent you wish to call.

- See Section “Alphanumeric keypad”, Page 6 for how to make the entry.

Erase

- If necessary, press the **Erase** key to erase the last character selected.

Consult

3. Press the **Consult** key to display the first answer.

- Successively press the **Next** key until the required name is displayed.

To go back to the previous name:

- Press the **Previous** key.

To change the entry:

- Press the **Correct** key.

Call

4. Press **Call** to call the correspondent whose name is displayed.
-> The terminal automatically calls the party.

Reminder: use the red  key to cancel or end a sequence.

Dialling a common abbreviated number

You will save time by using common abbreviated numbers. These numbers are programmable by the system manager and are accessible to all the subscribers.

* Terminal idle or already in communication:

1 - Press *.

3xxx
or _xxx

2 - Enter an abbreviated number (3xxx).

-> The set automatically dials the number.

Using the attendant console

Using the attendant console

When disabled, the attendant console does not have any telephone function.

However, depending on the features authorised by the operator, especially multi-line programming, a disabled attendant console can make and receive calls. We recommend that you contact your operator for more information.

Note: an Aastra 6757 set to attendant console mode and disabled does not find the features of an ordinary terminal (directory, logs, etc.).

Activating / deactivating the attendant console

Activating the attendant console function

When the attendant console function is disabled, a message on the display indicates this deactivation, and the indicator light associated with the programmed key **ON/OFF** goes on.

 **ON/OFF**

Confirm







1 - Press the programmed key **ON/OFF**.

-> The display prompts you to confirm the activation operation.

2 - Press the interactive **Confirm** key.

-> The indicator light associated with the programmed key **ON/OFF** goes off.

The display gives the information and features required to manage the attendant console function; these features are described in detail below.

	PE2:00	PE1:00	
	INT:00	TL:00	
	Comm		
	Status	More	
	Funct.	ABC	

Note: if an action is not confirmed within 5 seconds, the attendant console is deactivated.

More

Terminal idle; to display date and time:

- Press the interactive **More** key.

Using the attendant console

In case of network or power failure, the indicator light associated with the programmed key **MAJOR INCIDENT** blinks.

In this case:

- Contact the system manager.
- Then press the **MAJOR INCIDENT** key to acknowledge the alarm and switch off the associated indicator light. .



Deactivating the attendant console function

The attendant console function can only be deactivated if the terminal is not engaged in a communication *and outside CCO*. If some calls are waiting on the programmed **PUBLIC EXCHANGE 1** and **PUBLIC EXCHANGE 2** (*outside CCO*), they are automatically rerouted.



Confirm

1 - Press the programmed key **ON/OFF**.

-> The display prompts you to confirm the deactivation operation.

2 - Press the interactive **Confirm** key.

-> The indicator light associated with the program goes on. The display presents a message reminding you about the attendant console deactivation.

Note: if you fail to confirm within 5 seconds, the attendant console status returns to activated.

Caution: if, on a free attendant console, some incoming calls are not answered, the attendant console is automatically deactivated after a certain time. We recommend that you contact your operator to ask for this timeout to be adapted to your activities.

After deactivation and depending on the features programmed by the system manager, incoming calls will be forwarded to a predefined terminal, or announced by an external ring tone.

Using the attendant console

Answering calls

In active mode, the attendant console displays incoming calls and the indicator lights associated with the programmed keys blink.

Note: the terminal is free as long as at least one position is available, that is one free CCO key (indicator light off). A CCO is a conversation circuit; CCO keys enable you to handle several calls at the same time.

Incoming calls are classified into four categories based on their origin: external, internal, TL (tie line), or call return.

Answering an external call

The display alerts you when an external call arrives:

PE2:00	PE1:01
INT:00	TL:00

Moreover, the indicator light associated with the **PUBLIC EXCHANGE 1** key blinks.



- Press the programmed key **PUBLIC EXCHANGE 1** to talk to your correspondent.
-> The indicator light associated with this key goes off, unless another external call is on hold.



A communication circuit is then activated, and the indicator light associated with any of the supervision keys goes on (example: programmed key **CCO1**).

- > The display gives information about the origin of the call*:
- The physical location of the line
 - Caller's name (sometimes, this name is completed by the subscriber's number).

* Depending on the programming performed by the system operator.

Using the attendant console

Answering an internal call

The display alerts you when an internal call arrives:

PE2:00	PE1:00
INT:01	TL:00

Moreover, the indicator light associated with the **INTERNAL** key blinks.



INTERNAL

- Press the programmed key **INTERNAL** to talk to your correspondent.
 - > The indicator light associated with this key goes off, unless another internal call is on hold.



cco2

A communication circuit is then activated, and the indicator light associated with any of the supervision keys goes on (example: programmed key **CCO2**).

- > The display gives information about the origin of the call*:
 - The physical location of the line
 - Caller's name (sometimes, this name is completed by the subscriber's number).

Answering a TL call

The display alerts you when a tie line call arrives:

PE2:00	PE1:00
INT:00	TL:01

Moreover, the indicator light associated with the **TIE LINES** key blinks.



TIE LINES

- Press the programmed key **TIE LINES** to talk to your correspondent.
 - > The indicator light associated with this key goes off, unless another TL call is on hold.



cco3

A communication circuit is then activated, and the indicator light associated with any of the supervision keys goes on (example: programmed key **CCO3**).

- > The display gives information about the origin of the call*.

* Depending on the programming performed by the system operator.

Using the attendant console

Answering a returned call*:

You have transferred an external call to an internal extension.
This call has not been answered and is returned to you again.

PE2:01	PE1:00
INT:00	TL:00

The indicator light associated with the **PUBLIC EXCHANGE 2** key blinks.



PUBLIC EXCHANGE 2

- Press the programmed key **PUBLIC EXCHANGE 2** to talk to your correspondent.
-> The indicator light associated with this key goes off, unless another returned call is on hold.

A communication circuit is then activated, and the indicator light associated with any of the supervision keys goes on (example: programmed key **CCO4**).



cco4

- > The display gives information about the origin of the call*:
- The type of return (Public exchange - TL)
 - The name and number of the owner of the extension that did not answer
 - The name of the company and department
 - The reason why the call was returned (do not disturb - no answer - busy)
 - inaccessible - forwarded - not assigned - blocked).

Note:

- Depending on the settings (See "Choosing how to be alerted to incoming calls" on page 50.), a call coming in during an ongoing call can be indicated by a beep and a blinking indicator light associated with the programmed key.
- Pressing any of the **PUBLIC EXCHANGE** keys puts an ongoing call automatically on hold.
- You can resume a call on hold by pressing the **CCO** key with a flashing indicator light.

* Depending on the programming performed by the system operator.

Managing call overload

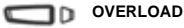

The purpose of the indicator light associated with the **OVERLOAD** key is to alert you to the arrival of one or more unanswered calls:

- **first level overload**: the indicator light associated with the key goes on, indicating that a new call has arrived whereas all the operators are busy.

- **second level overload**: the indicator light associated with the key blinks, indicating calls not answered in the last 20 to 40 seconds* or more waiting calls than available attendants (only for network calls).

* These alerts are set off after a specific timeout. We recommend that you contact your operator to ask for this timeout to be adapted to your activities.

- Press the **OVERLOAD** key to display incoming calls on hold.

Using the attendant console

Making a call

To make a call, you may dial the number directly on the keypad or use the call modes described below. This action automatically sets off an enquiry call if a call is already in progress.

Calling an internal party



- Dial the party's extension number.
->The display shows the name of the party*.

When the called party answers, you can talk.

Calling an external party

0

1 - Dial the outside line access code (**0**) or .



2 - Dial the party's number.

-> The display shows the number dialled.

Calling a party by his or her name:

ABC

See Section "Calling a correspondent by name", Page 10.

Using programmable keys



The available programmable keys can be assigned to the numbers of parties that you call regularly (internal or external).

- Press the programmed key.

->The terminal calls the party automatically. The display shows the party's number.

Using the LNR function



The LNR (last number redial) function is used to automatically redial the last number that was dialled.

- Press the green key.

-> The terminal calls the party automatically. The display shows the number called.

Using the attendant console

Other features*:

Depending on the programming made by the system manager, pressing the **Comm** key gives access to other features. Example:

- To access the list of emergency numbers, successively press the interactive **Comm** keys (-->*), **Emergency** key then dial the emergency number.

Contact your system manager for more information.

Viewing the status of a terminal

This function is used to view the status of an extension in the company while continuing the conversation with a calling party.

Note: this feature is also available off line.

During a call:

Prenum

- 1 - Press the interactive **Prenum** key.

Status

- 2 - Press the interactive **Status** key.

Note: terminal idle, the display gives direct access to this function.
-> The display prompts you to enter the number of the extension of which you wish to know the number.



- 3 - Dial the first number of the extension.

-> The display gives the status of the extension.

Call

To call a free terminal

- Press the **Call** key.
- > The display gives the various features available during a call.

Call

To alert a party whose line is busy

- Press the **Call** key.
- > The party is notified about your call with a beep; he has the possibility to or not to answer your call.

Recover

- If you wish to resume the conversation with the caller, press the interactive **Recover** key.

* Depending on the programming performed by the system operator.

Using the attendant console

Intrude

To intrude as a third party on a busy terminal

1 - Press the interactive **Intrude** key.

-> You are connected with both parties.

Mute

2 - Press the interactive **Mute** key to speak with the internal correspondent while putting the other party on hold.

Recover

3 - Press the interactive **Recover** key to end the intrusion.

Recover

4 - Press again the interactive **Recover** key to resume conversation with the waiting party.

- If you wish to call a new extension, press the interactive **Other** key; otherwise press the interactive **Return** key to exit.

Alerting a correspondent:

When the party you wish to reach does not answer, you can send him or her a short message on his or her terminal display, provided this (internal or external) correspondent is connected to a digital interface.

Notify

1 - Press the interactive Notify key.

-> The display shows the first six predefined messages.

More

2 - Press successively the interactive **More** key to possibly select another predefined message or the free message.

- Depending on the option, you must complete the message presented or write a free message on the keypad (See "Alphanumeric keypad" on page 6.).

- To possibly correct an input, press the interactive **Erase** key.

Enter

3 - Press the interactive **Enter** key to confirm the message send request.

-> The display proposes to resume the call.

No

4 - Press the interactive **Yes** or **No** (example) key, depending on the case.

Notes: the predefined messages are directly displayed on the terminal of the alerted correspondent. On the other hand, a free message is not displayed directly; the correspondent is alerted to an incoming written message and must go to view it.

Using the attendant console

During a call

Transferring a call to a terminal

You are engaged in a call and wish to transfer the call to an internal terminal.



Transfer

1 - Dial the **number of the terminal** directly.

Note: you can also make a search by name or use the preprogrammed keys.

2 - Press the interactive **Transfer** key.

-> The indicator light associated with the CCO key goes off*.

Transferring a call to several terminals successively (chaining)

The external correspondent wishes to speak to several persons successively.

-->

1 - Press the interactive --> key.

Chaining

2 - Press the interactive **Chaining** key.



3 - Dial the **number of the terminal** directly.

Note: you can also make a search by name or use the preprogrammed keys.

If you want, you can wait for the called party to answer before transferring.

At the end of the conversation, when the internal correspondent on-hooks, the external correspondent is automatically presented as **PUBLIC EXCHANGE 2** to request to be transferred to another internal terminal.

Returning to the first correspondent

You have called an internal correspondent and he or she fails to answer.

Recover

• Press the **Recover** key.

You can also press the red  key.

-> You will recover the party who was on hold.

* Depending on the programming performed by the system operator.

Using the attendant console

Switching from one party to the other

You want to successively switch from one party to the other.

Shuttle

- Press the interactive **Shuttle** key.
- > You talk alternately with each party, but they cannot communicate with one another. The party presented on the second display line is always the one on hold.

Setting up a conference call

You want to talk to both parties at the same time (feature granted if you made the last call).

-->

Conf

- Press the interactive **-->** key then the interactive **Conf** key.
- > A three-way conference call is set up between you and your two parties. If one of them hangs up, you stay on line with the other.

During the conference call, if you want to leave your two parties talking to one another: To end the conference:

Transfer

- Press the interactive **Transfer** key.
- > The two parties stay in communication.

Note: if it fails, your set rings again.

Returning with a correspondent put on hold on another CCO

Pressing any of the **PUBLIC EXCHANGE 1 / 2 - TIE LINES** or **INTERNAL** keys puts an ongoing call automatically on hold.

 cco4

- Press the CCO key with a flashing indicator light. You may resume conversation with the party on hold.

Note: it is not possible to set up a conference between two correspondents present on two different CCOs.

Using the attendant console

Using the mute function

The call is set up with a party and you want to have a confidential conversation without the party being able to hear it.



1 - Press .

-> The handset, handsfree or headset microphone is cut and the indicator light associated with the key is steady on. Your correspondent does not hear you.



2 - Press the  key again to resume conversation with the correspondent.

-> The indicator light associated with the key goes off.

Displaying time

During a call, you can display date and time instead of the name and/or number of your correspondent:

-->

1 - Press the interactive --> key.

Time

2 - Press the interactive **Time** key.
-> The date and time are displayed.

Using the attendant console

Using the trace function

You want the number of the called or calling party (internal or external) to be written in the logbook, for example, to identify a malicious call.

During a call:



-->

1 - Press the interactive --> key.



Trace

2 - Press the interactive **Trace** key.

-> The number is automatically stored in the logbook that can be consulted by the system operator.

Saving the correspondent's number

Whether you are calling or being called, you can save your correspondent's number on a programmable key.



-->

1 - Press successively the interactive --> key.



Memory

2 - Press the interactive **Memory** key.



3 - Press any programmable key.

-> The number is automatically memorised and accessible from this programmable key.

Note: indicate the name of the correspondent on the label for the programmed key.

Ending a call.



• Press the red  key.

-> If the terminal was in handsfree or headset mode, the indicator light associated with the  key goes off.
The line becomes free. The call is ended.

Note: after a call is processed, when the attendant console returns to standby mode, the display remains "blank" for a few seconds. However, the attendant console continues to work normally and any operation (especially answering a call) is taken into account.

Attendant console services

The attendant console offers a certain number of customizable services.

Funct.	1 - Press the interactive Funct. key.
Server	2 - Press the interactive Server key. -> The display presents the first available column.
More	• Press successively the More key to display the other columns.
Access	3 - Press the interactive Access key when the display presents the required column.
Previous	While viewing a column: • Pressing the interactive Previous key returns you to the beginning of the column.
Content	• Pressing the interactive Content key returns you to the list of columns.

Reserving external lines *

This function is used to reserve an external trunk group for outgoing calls on the attendant console *.

Note: this function is also available via the programmed RESERVED LINES key (See "Attendant console operating keys" on page 3.).

When you have accessed the "EXTERNAL LINE RESERVATION" column

Reserv	To reserve a line • Press the interactive Reserv key.
--------	--

Cancel	To cancel a line reservation • Press the interactive Cancel key.
--------	---

Reminder: use the red  key to end a sequence and return to idle mode.

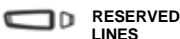

In idle mode, you can access this menu directly by pressing the **RESERVED LINES** key.

-> The indicator light associated with this key goes steady on to remind you to reserve lines.

* Depending on the programming performed by the system operator.

Attendant console services

Programming and managing the system *

This function is used to:

- View a terminal's telephone consumption
- Manage restriction mode management
- Manage date and time

When you have accessed the "SYSTEM MANAGEMENT" heading.

View a terminal's telephone consumption:

This function lets you know the number of telephone charging units billed for a given terminal on the installation, from the last time its counter was reset.

Invoice

- 1 - Press the interactive **Invoice** key.
-> The display prompts you to enter the number of the extension of which you wish to know the consumption.



- 2 - Dial the extension number.
 - In case of error, press the interactive **Erase** key.

Enter

- 1 - Press the interactive **Enter** key.
-> The display presents the counter and reset date.

To reset the counter:

Cancel

- Press the interactive **Cancel** key, then

Yes

- Press **Yes** to confirm.

Note: a password is not required the first time you are cancelling so long as you do not exit the Invoice menu. Contact the system manager to obtain it.

To view the consumption of another terminal:

Other

- Press the interactive **Other** key.

Reminder: use the red  key to end a sequence and return to idle mode.

Attendant console services

Managing restriction modes

Installation user rights are granted by the operator and may vary according to time of the day. **Example:** some international calls may be authorised in the day and local calls only in the evenings or at the weekend.

This function is used to force the system into either modes.

Timetab.

1 - Press the interactive **Timetab.** key.

-> The display prompts you to select the operating mode.

Night

2 - Press the interactive **Day** or **Night** key (Night for example).

-> The display confirms the selected restriction.

Reminder: use the red  key to end a sequence and return to idle mode.

Changing the system date

This function is used to change the date programmed in the system.

Date

1 - Press the interactive **Date** key.

-> The screen prompts you to enter the new date.

DDMMYYYY

2 - Enter the new date in DDMMYYYY format.

Enter

3 - Press the interactive **Enter** key to finish.

-> The display presents the programmed date.

To modify the date again:

Modify

• Press the interactive **Modify** key.

You can also modify the time directly by pressing the interactive **Time** key (see below).

Reminder: use the red  key to end a sequence and return to idle mode.

Managing the system time

This function is used to change the time programmed in the system.

Time

1 - Press the interactive **Time** key.

-> The screen prompts you to enter the new time.

Attendant console services

HHMMSS

2 - Enter the new time in HHMMSS format (hours, minutes and seconds).

Enter

3 - Press the interactive **Enter** key to finish.

- You can also put the time forward or backward by one hour, by pressing directly the corresponding interactive key (+ 1 H or - 1 H).

-> The display presents the programmed time.

To change the time again:

Modify

- Press the interactive **Modify** key.

Reminder: use the red  key to end a sequence and return to idle mode.

Using the hotel function

This function gives access to the various services associated with a customer or a given room:

- Declaring an arrival
- Declaring a departure
- Programming wake-up
- Declaring a phone box.

Important note: if you use these functions frequently, your system manager can program some keys that give direct access to each of them.

When you have accessed the "HOTEL MANAGEMENT" heading.

Declaring an arrival

This function is used to open up direct access to the public switched network for the phone in a hotel room.

Arrival



1 - Press the interactive **Arrival** key.

-> The display prompts you to enter the room extension number.

2 - Dial the **extension number**.

- In case of error, press the interactive **Erase** key.

Enter

3 - Press the interactive **Enter** key.

-> The display confirms the operation and proposes to declare another arrival.

Reminder: use the red  key to end a sequence and return to idle mode.

Attendant console services

Declaring a departure

This function is used to deactivate access to the public switched network for the telephone in a hotel room.

Depart.



- 1 - Press the interactive **Depart.** key.
-> The display prompts you to enter the room extension number.
- 2 - Dial the **extension number**.
 - In case of error, press the interactive **Rubout** key.

Enter

- 3 - Press the interactive **Enter** key.
-> The display indicates the cost (in local currency) of calls made from the room extension since the customer arrived.

Euro

To display the cost in euros:

- Press the interactive **Euro** key.

To return to the display in local currency, press the interactive **Change** key.

Ticket

To print out a receipt on the system printer:

- Press the interactive **Ticket** key.

Confirm

To definitely close the room's account: :

- Press the interactive **Confirm** key.

-> The display proposes to declare another departure.

Cancel

To cancel the declaration of departure:

- Press the interactive **Cancel**key.

Reminder: use the red  key to end a sequence and return to idle mode.

Programming an alarm (wake-up)

This function is used to set an alarm for a given room.

Wake-up



- 1 - Press the interactive **Wake-up** key.
-> The display prompts you to enter the room extension number.
- 2 - Dial the **extension number**.
 - In case of error, press the interactive **Erase** key.

Enter

- 3 - Press the interactive **Enter** key.

Attendant console services

Activ.

4 - Press the interactive **Activ.** key.

HHMM

5 - Enter the wake-up time you want (HHMM format, i.e. hours and minutes).

Enter

6 - Press the interactive **Enter** key.
-> The display confirms the programmed wake-up operation.

Modify

To change the wake-up time:

- Press the interactive **Modify** key.

Cancel

To cancel the alarm:

- Press the interactive **Cancel** key.

Next

To access the wake-up programming of another terminal:

- Press the interactive **Next** key.

The terminal will ring at the set time.

Reminder: use the red  key to end a sequence and return to idle mode.

Attendant console services

Declaring a phonebox

This function is used to temporarily authorise calls from a terminal managed from an attendant console.

Phonebox



- 1 - Press the interactive **Phonebox** key.
-> The display prompts you to enter the required extension number.
- 2 - Dial the box **extension number**.
 - In case of error, press the interactive **Erase** key.
-> The display proposes to assign this box to a customer or to qualify it as a temporary box.

Guest



- 1 - Press the interactive **Guest** key for example.
-> The display prompts you to enter the customer's extension number.
- 2 - Dial the customer's **extension number**.
 - In case of error, press the interactive **Erase** key.

Enter

- 3 - Press the interactive **Enter** key.
The communication cost will automatically be added to the room account.

• For a temporary box:

Press the interactive **Visitor** key.

A few seconds after the end of the call from the phone box, the attendant console is called.

Press the programmed **INTERNAL** key.

-> The display gives the unit cost of the call charges: "CALLBACK PHONEBOX XXX COST XXXX UNITS".

Caution: after use and depending on the features granted by the manager, the phone box may disallow external calls until next activation by the attendant console.

Reminder: use the red  key to end a sequence and return to idle mode.

Attendant console services

Displaying calls

This function gives the status of a terminal and indicates the internal or external participants in a conversation.

When you have accessed the "DISPLAY COMMUNICATIONS" heading.

Phone bk



1 - Press the interactive **Phone bk** key.

2 - Dial the **number of the terminal** on which you wish to obtain some information.

- In case of error, press the interactive **Erase** key.

Enter

3 - Press the interactive **Enter** key.

-> The display gives the terminal status.

If the terminal is engaged in a call:

The display indicates the internal or external correspondent (if connected to the digital network) with whom the conversation is held.

- Press the interactive **Distant** key.

-> The display gives the number entered previously.

Distant

Note: the interactive **Port** key is reserved for the system operator.

If the terminal is not engaged in a call:

The display confirms this status.

To select another terminal:

- Press the interactive **Other** key.

Other

Reminder: use the red  key to end a sequence and return to idle mode.

Displaying trunk line statuses

This function gives the status of trunk lines and more especially those meant for the system manager.

The screen shows "DISPLAY STATUS OF TRUNKS LINES".

Attendant console services

Monitoring grouped lines *

This function is used to display the telephone traffic on a group of terminals. Your system manager will communicate the groups' call numbers to you.

When you have accessed the "GROUPED LINE SUPERVISION" heading.

The display prompts you to enter the grouped line number.



1 - Dial the **number of the grouped line** on which you wish to obtain some information.

- In case of error, press the interactive **Erase** key.

Enter

2 - Press the interactive **Enter** key.

-> The display gives the number of waiting calls.

More

To obtain more information:

- Press the interactive **More** key.

-> The display gives the timeout for the return of these calls to the attendant console.

Previous

To view the status of another hunt group:

- Press the interactive **Previous** key, then proceed from step 1.

Reminder: use the red  key to end a sequence and return to idle mode.

Notifying a correspondent

This function (also accessible during a call, (See "Making a call" on page 18.)), is used to send a short message to a correspondent, provided this correspondent is connected to a digital interface.

Set idle,

Funct.

1 - Press the interactive **Funct.** key then the interactive **Notify** key.

Notify



2 - Dial the **number of the correspondent** to be notified then press the interactive **Enter** key.

-> The display shows the first six predefined messages.

Enter

* Consult the system manager.

Attendant console services

More

- 3 - Press successively the interactive **More** key to possibly select another predefined message.
- Depending on the choice, you must complete the message presented or write a free message on the alphanumeric keypad (on two lines of 13 and 19 characters).
 - To possibly correct an input, press the interactive **Erase** key.

Enter

- 4 - Press the interactive **Enter** key to confirm the message send request.
- > The display confirms the message transmission.

Programmable keys

You call some parties or colleagues several times a day...

You frequently use some telephone functions such as forwarding or supervision.

The programmable keys on your terminal can be used to store these numbers or functions and easily access the services offered (See "Description of the terminal" on page 1.).

Programming a key

Regardless of the type of programming (number or function), the access procedure is identical.

Funct.

1 - Press the interactive **Funct.** key.

Program

1 - Press the interactive **Program** key.

-> The following question appears on the display:
"WHAT DO YOU WANT TO PROGRAM?"

Key

2 - Press the interactive **Key** key.

-> The display prompts you to select the programmable key you want.



3 - Press any programmable key.

-> The indicator light associated with this key goes on and the display gives the status of this key's programming.

Modify

4 - Press the interactive **Modify** key.

-> During programming, the indicator light associated with the key blinks.

You have access to the various programming types described briefly below. We recommend that you refer to the chapters that specifically describe these functions for more information on the features available.

Programmable keys

Programming a number



Number



Erase

Enter

You can program the call number for an internal or external party.

After selecting the key to be programmed (the associated indicator light blinks):

1 - Press the interactive **Number** key.

-> The display prompts you to enter the number.

2 - Dial the **party's number** without forgetting the network access code if it is an external party (0 by default).

• In case of error, press the interactive **Erase** key.

3 - Press the interactive **Enter** key to confirm the programming.

-> The display presents the key's programming.

You can thus call your correspondent by simply pressing this key.

Programming supervision



Superv.

Extens.

Other



Enter

Mute

You can program the supervision function for another terminal or your own terminal.

After selecting the key to be programmed (the associated indicator light blinks):

1 - Press the interactive **Superv.** key.

-> The display prompts you to choose the type of supervision (voicemail, terminal or external line).

2 - Press the interactive **Extens.** key for example.

-> The display proposes to supervise your own terminal or another terminal.

3 - Press the interactive **Other** key to supervise another terminal, for instance.

-> The display prompts you to enter the number of the terminal you wish to supervise.

4 - Dial the **extension number** then press the interactive **Enter** key.

-> The display prompts you to choose how the supervised terminal will alert you.

5 - Press the interactive **Mute** key for example.

-> The display presents the key's programming.

Therefore, you have a continuous view of the supervised set's telephone activity and can intervene by simply pressing this key.

Programmable keys

Program a series of codes:

This is to program a series of codes that will be interpreted by the set that already has a call in progress. You can, for instance, program a server's access sequence.



After selecting the key to be programmed (the associated indicator light blinks):

Tone

1 - Press the interactive **Tone** key.
-> The screen prompts you to dial the code.

<Sequence>

2 - Enter the **sequence**.
Example: enter the access code for a server followed by #.
• In case of error, press the interactive **Rubout** key.
• To insert a pause between two series of codes, press the interactive **Pause1** or **Pause2** * key.

Enter

3 - Press the interactive **Enter** key to confirm the programming.
-> The display presents the key's programming.

Thus, by simply pressing this key, you give the terminal with a call in progress all the information required and quickly access the required service.

Erasing, modifying, exiting programming

After you have programmed a key, the display gives the programming status of this key and offers various possibilities.

Erase

1 - Press the interactive **Erase** key to delete the programming displayed.

Modify

2 - Press the interactive **Modify** key and resume the previously described procedure to modify the displayed programming.

Start



3 - Press the interactive **Start** key to return to the beginning and program another key.

** Depending on the programming performed by the system operator.*

End

4 - Press the interactive **End** key to exit the programming.

Reminder:during programming,

- pressing the red  key cancels the current settings.
- Pressing the red  key twice ends a programming sequence.

Programmable keys

Identifying programmed keys

Labels are available on the internet in form of an electronic document. You can use them to indicate, for each key, the name of the correspondent or programmed key (the internet address is available on the last page of this document).

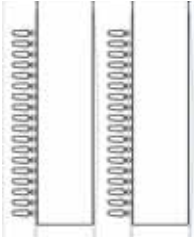

- 1 - Fill in the fields directly from the PC. Then print out the document and cut off the label.
- 2 - Carefully remove the transparent cover of the extension module.
- 3 - Place the label on the system.
- 4 - Place back the transparent cover.

The supervision function

When programmed on your telephone, the supervision of a set of terminals* enables you to:

- Know the status of supervised terminals (free, called, busy)
- Call these terminals directly.

Note:the supervision of an outside line or network line can also be programmed. In these specific cases, we recommend that you consult your system operator.

Programming the supervision function

You want to program the supervision of a terminal on a programmable key:

Funct.

1 - Press the interactive **Funct.** key.

Program

2 - Press the interactive **Program** key.

-> The following question appears on the display:
"WHAT DO YOU WANT TO PROGRAM?"

Key

3 - Press the interactive **Key** key.

-> The display prompts you to select the programmable key you want.



4 - Press any programmable key.

-> The indicator light associated with this key goes on and the display gives the status of this key's programming.

Modify

5 - Press the interactive **Modify** key.

Superv.

6 - Press the interactive **Superv.** key.

-> The following question appears on the display:
"WHAT DO YOU WANT TO SUPERVISE?"

Extens.

7 - Press the interactive **Extens.** key.

-> The display proposes to supervise your terminal or another terminal.

* Depending on the programming performed by the system operator.

The supervision function

Other



Enter

- 8 - Press the interactive **Other** key to supervise another terminal.
-> The display prompts you to enter the number of the terminal you wish to supervise.
- 9 - Dial the extension number then press the interactive **Enter** key.
-> Caution: although the display prompts you to choose how the supervised terminal will alert you, this function is not available on this terminal.

Communicating with the supervision function

You have programmed the supervision function of a set on a programmable key.

On your terminal, the status of the indicator light associated with the programmed key varies according to the status of the supervised terminal.



- When the supervised terminal is in standby mode, the indicator associated with the key is off.
- When the line of the supervised terminal is busy, the indicator associated with the key is on.

Transferring an incoming call to the supervised terminal

You are in communication with a party and you want to transfer the call to the supervised terminal:



Transfer

- Press the **programmed key** then the interactive **Transfer** key.
-> The indicator light associated with the program goes on.

Calling the supervised terminal

To call the owner of the supervised terminal:



- Press the **programmed key**.
-> The indicator light associated with the program goes on.

Multi-key function

By default, the attendant console has only one directory number* and six customised keys enabling it to handle several calls at the same time (CCO1 to CCO6).

It is possible to increase the number of programmed keys or CCOs. The use of these programmed keys or CCOs is the same as the one described in Chapter "Using the attendant console", Page 12.

Example: for eight simultaneous calls, you must program the multi-key function on additional two keys.

Programming the multi-key function

To program the multi-key function:

- | | |
|---|--|
| Func. | 1 - Press the interactive Func. key. |
| Program | 2 - Press the interactive Program key.
-> The following question appears on the display:
"WHAT DO YOU WANT TO PROGRAM?" |
| Key | 3 - Press the interactive Key key.
-> The display prompts you to select the programmable key you want. |
|  | 4 - Press any programmable key.
-> The indicator light associated with this key goes on and the display gives the status of this key's programming. |
| Modify | 5 - Press the interactive Modify key. |
| Superv. | 6 - Press the interactive Superv. key.
-> The following question appears on the display:
"WHAT DO YOU WANT TO SUPERVISE?" |
| Extens. | 7 - Press the interactive Extens. key.
-> The display proposes to supervise your terminal or another terminal. |
| Me | 8 - Press the interactive Me key to supervise your terminal.
-> The display gives the number of keys already programmed for this. |

* Depending on the programming performed by the system operator.

Multi-key function

Add

9 - Press the interactive **Add** key to confirm the new programming.
-> The display gives the number of keys already programmed for this.

<- Start

10 - Press the interactive **<-Start** key then start programming the multi-key function on at least one other programmable key.

Reminder: use the red  key to cancel a setting or return to standby mode.

The multi-line function*

An attendant console used in multi-line mode has a second directory number stored on one or more programmable keys (enquiry call management).

This function is mainly used to program on the attendant console a private number, for instance, that lets you make and receive calls:

Examples:

Attendant console enabled

For an attendant also working as assistant, this is the private number for calls associated with this second function.

Attendant console disabled

This is a predefined number to which calls are forwarded (example night forwarding service terminal).

Programming the multi-line function

You will program the supervision function for each of the two directory numbers.

Funct.

1 - Press the interactive **Funct.** key.

Program

2 - Press the interactive **Program** key.

-> The following question appears on the display:
"WHAT DO YOU WANT TO PROGRAM?"

Key

3 - Press the interactive **Key** key.

-> The display prompts you to select the programmable key you want.



4 - Press any programmable key.

We recommend that you use the **L1** key.

-> The indicator light associated with this key goes on and the display gives the status of this key's programming.

Modify

5 - Press the interactive **Modify** key.

Superv.

6 - Press the interactive **Superv.** key.

-> The following question appears on the display:
"WHAT DO YOU WANT TO SUPERVISE?"

* Depending on the programming performed by the system operator.

The multi-line function

Extens.

7 - Press the interactive **Extens.** key.

-> The display proposes to supervise your terminal or another terminal.

Me

8 - Press the interactive **Me** key to supervise your terminal.

-> The display gives the number of keys set already to supervision mode for this directory number.

More

9 - Press the interactive More key.

-> The display gives the number of keys set already to supervision mode for this second directory number.

Add

10 - Press the interactive **Add** key to confirm the new programming.

-> The display confirms the key's programming.

<- Start

11 - Press the interactive **<-Start** key then program the multi-line function on as many keys as the calls you wish to handle simultaneously on this second directory number.

Warning

Your terminal is now set to multi-line mode.

Attendant console enabled, you will receive calls meant for the second directory number using the keys programmed as indicated below.

Attendant console disabled, your A6757 becomes a simple terminal and gives you access to a certain number of features.

We advise you to contact your system manager should you require more information.

Communicating with the multi-line function when attendant console enabled mode

Answering a call

When a call arrives on your terminal in multi-line mode, the indicator light associated with the personalised key blinks.

Caution: the phone does not ring.



- Press this programmed key to talk with the correspondent.
-> The indicator light associated with this key goes steady on. The display shows the calling party's identity.

Answer a second call:

If another party tries to reach you on the second line, the indicator light of a second key blinks.



- Press the programmed key associated with the blinking indicator light.

While in communication with the second party.

-> The indicator light associated with the key goes steady on and the display gives the identity of the correspondent engaged in a conversation.

The first party is put on hold.

-> The indicator light associated with this key blinks rapidly.

Switching from one party to the other

You are in communication with one party with another party on hold.



- Successively press the programmed key with the rapidly blinking indicator light to switch from one party to the other.

-> The indicator light associated with the key of the party you are talking to goes steady on and the display gives his or her identity.

-> The indicator light associated with the key of the party on hold blinks rapidly.

The multi-line function

Communicating with the multi-line function in attendant console disabled mode

Answering a call:



When a call arrives on your terminal in multi-line mode, the terminal rings and the indicator light associated with the personalised key blinks.

- Press this programmed key to talk with the correspondent.

-> The indicator light associated with this key goes steady on. The display shows the calling party's identity.

Some additional features are proposed during calls:

. Press the interactive **Parking** key to continue with the call set up with the correspondent, on another terminal in another office. On the second terminal, you must successively press **Pick-up** then **Parking** before dialling the number of the first terminal.

. Press the interactive **-->** key then **Record** (*) to record the conversation in progress.

Caution: recording a person's conversation without notifying him or her may be considered as an offence in the eyes of the law.

These features are specific to individual terminals and can be programmed. Contact your system manager for more information.*

Answering a second call



If another party tries to reach you on the second line, you will hear a beep and the indicator of a second key flashes.

- 1 - Press the interactive **Wait** key to see the caller's identity.

If you do not wish to answer:

- Press the interactive **Divert** key.
- then dial the **number of the extension** to which you wish to divert the call.

- 2 - Press the interactive **Answer** key.

You can also press the **programmed key** associated with the blinking indicator light.

While in communication with the second party.

-> The indicator light associated with the key goes steady on and the display gives the identity of the correspondent engaged in a conversation.



The first party is put on hold.

-> The indicator light associated with this key blinks rapidly.

Wait

Divert



Answer

Switching from one party to the other



You are in communication with one party with another party on hold.

- Successively press the programmed key with the rapidly blinking indicator light to switch from one party to the other.
- > The indicator light associated with the key of the party you are talking to goes steady on and the display gives his or her identity.
- > The indicator light associated with the key of the party on hold blinks rapidly.

Set settings

Set settings

Choosing and adjusting the terminal ring tone

You can choose a ring tone (16 different ring tones) and adjust the ringer volume (8 levels).



1 - Press Tools.



-> The display indicates "RING".

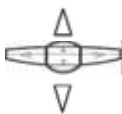

2 - Press **OK**.

-> The display indicates the number of the current ring tone.





3 - Press successively the  or  keys to access the various ringer settings.

Choosing and setting the current ring tone





The display indicates "RING MELODY: xx".

• Press successively the  or  keys to choose the current ring tone.

Note*: by default, the correspondents stored in the private directory are displayed to you, during their call, with ring tone number 8. Therefore, we advise you to choose another ring tone for the current ringer.

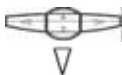

Each time a key is pressed, the corresponding ring tone is broadcast and the display indicates the number.



• Press .

-> The following question appears on the display:
"RING VOLUME: x".



• Successively press the  or  keys to adjust the current ringer volume. The volume can be adjusted with 8 levels, including ringer off.

Each time a key is pressed, the ring tone is broadcast with the new volume and the display indicates this level.

Replacing the ring tone

When a call arrives, you can temporarily replace the ring tone (beeps) or disable it (mute). However, in case of no answer, the ring tone is restored.

Funct.

1 - Press the interactive **Funct.** key.

Program

2 - Press the interactive **Program** key.
-> The display shows "**WHAT DO YOU WANT TO PROGRAM?**"

Ring tone

3 - Press the interactive **Ring tone** key.
-> The display proposes two signalling modes.

D.N.D

If you wish to disable the melody,
Press the interactive **D.N.D** key.

Beep

• **If you wish to replace the ring tone with beeps,**
Press the interactive **Beep** key.

To restore the initial ring tone, press the interactive **Normal** key.

Choosing how to be alerted to incoming calls

Depending on the settings, during a call, you may be alerted by an audible beep to an incoming new call.

Funct. t

1 - Press the interactive **Funct.** key.

Program

2 - Press the interactive **Program** key.
-> The display shows "**WHAT DO YOU WANT TO PROGRAM?**"

Signal

3 - Press the interactive **Signal** key.
-> The display proposes two signalling modes.

Modify

4 - Press the interactive **Modify** key.
-> The display gives the new signalling status of incoming calls.

Depending on the case, an incoming call may or may not be signalled by a beep in addition to the blinking indicator light.

Adjusting the screen contrast

You can adjust the screen contrast over 8 levels.

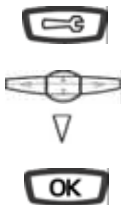

1 - Press Tools.

2 - Press successively the  key until "**DISPLAY**" is displayed.

3 - Press **OK**.
-> The display indicates the current contrast level.

Set settings



- Successively press the ◀ or ▶ keys to adjust the display contrast.
- > Each time a button is pressed, the contrast changes and the display indicates the new level.



- 4 - Press **OK** to confirm the settings.

Adjusting the volume level of the beeps heard when a key is pressed

A beep is activated each time a key is pressed. The volume of this beep can be adjusted over 8 levels; the lowest level corresponds to no beep.

Idle:



- Successively press the ◀ or ▶ keys to reduce or increase the volume of the sound heard when a key is pressed.
- > After each key press, the new setting is played. The set stores the last setting.

Choosing the terminal language

You can choose the language in which all the screen messages will be displayed.

Funct.

- 1 - Press the interactive **Funct.** key.

Program

- 2 - Press the interactive **Program** key.
- > The display shows "WHAT DO YOU WANT TO PROGRAM?"

Language

- 1 - Press the interactive **Language** key.

English

- 2 - Press the interactive key corresponding to the language you want (**English** for example).
- > All the messages broadcast by the display will be presented in the same language.

Choosing how to be alerted to incoming calls

Depending on the settings, during a call, you may be alerted by an audible beep to an incoming new call.

Funct.	1 - Press the interactive Funct. key.
Program	2 - Press the interactive Program key. -> The display shows "WHAT DO YOU WANT TO PROGRAM?"
Signal	3 - Press the interactive Signal key. -> The display gives the signal status.
Modify	4 - Press the interactive Modify key. -> The display gives the new signalling status of incoming calls.

Depending on the case, an incoming call may or may not be signalled by a beep in addition to the blinking indicator light.

Programming automatic answer *

Depending on the configuration, you can choose to automate call answering. In this case, calls pass directly via CC, without any action on your part.

Funct.	1 - Press the interactive Funct. key.
Program	2 - Press the interactive Program key. -> The display shows "WHAT DO YOU WANT TO PROGRAM?"
Answer	3 - Press the interactive Answer key. -> The display gives the signal status.
Edit	4 - Press the interactive Edit key. -> The display confirms that you are in automatic answering mode.

We advise you to contact your system manager for information on how to use this function.

* Depending on the programming performed by the system operator.

Miscellaneous

Glossary (terms you need to know)

Conference call	Three-way call from a call with two parties.
Intercept group	Group of sets associated to the same group and authorised to intercept calls intended for this group.
Tie lines	Tie lines connect one company site directly with another.
External line	A line connected to the public network
Digital	Refers to a terminal with access to ISDN services.
Handsfree	Telephony mode used to make and receive calls without lifting the handset.
Multi-line subscribers	A terminal with several directory numbers.
Multi-key	A terminal with only one directory number, but several programmed keys for managing several calls simultaneously.
Directory of internal names	This is the common directory of names of internal correspondents, recorded in the system by the system manager.
Directory of external names	This is the common directory of names of external correspondents, recorded in the system by the system manager.
Directory of common abbreviated numbers	This is the directory of common abbreviated numbers recorded in the system by the system manager.

Troubleshooting Check...

Fault detected

Possible causes

No display

Check that the set is connected to the line (dial tone in the earpiece).

Check the cord to connect to the line.

Check that the other sets in the installation are working.

Check the screen contrast setting.

No dial tone

Check that the set is connected to the line (display).

Check the cord to connect the handset.

Check that the other sets in the installation are working.

Check the handset, loudspeaker or headset volume settings.

No sound

Check the handset, loudspeaker or headset volume settings.

Messages displayed in a foreign language

Check the chosen display language.

Installing the terminal

Installing the terminal

Connections

Connecting the handset

Turn the telephone and identify the marked handset socket . Insert one end of the handset cable in the socket until it locks with a click, then slip the cable into the slot, as shown in the following diagram. Connect the handset to the other end of the cable.

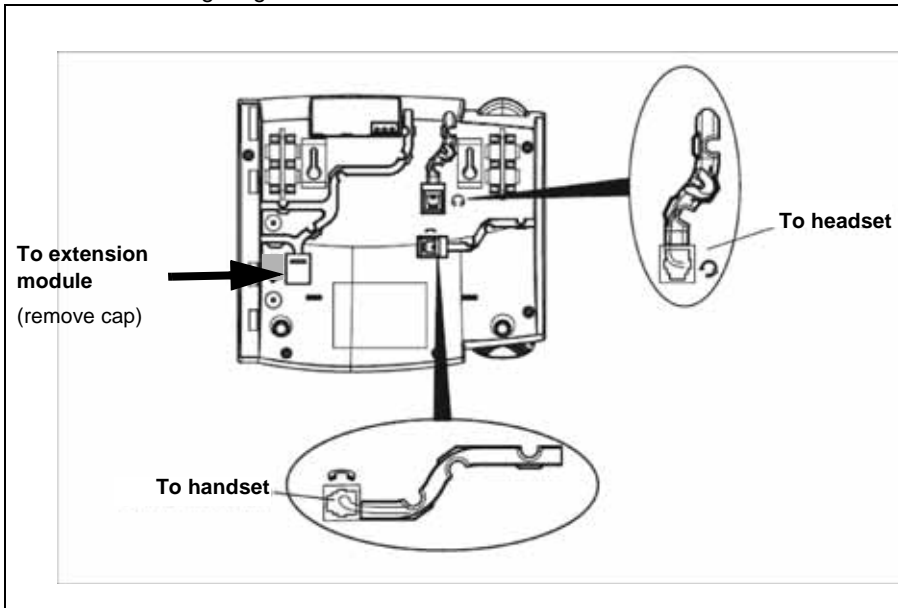

Connecting a headset (optional on Aastra 6755 and 6757)

Turn the telephone and identify the marked headset socket . Insert the headset cable connector in the socket until it locks. Then slip the cable into the plug as shown in the diagram below.

Connecting to the telephone network

You can connect to the telephone network with the cable delivered with the terminal:

- RJ45 type male socket for wall connection
- RJ11 type male socket for connection on the terminal side.

The network socket on the telephone is located at the back of the terminal, on the location marked . Insert the RJ11 socket of the network connection cable in the socket until it unlocks. Connect the end of RJ45 to the wall socket.

Installing the terminal

The standard connection of the terminals is as follows:

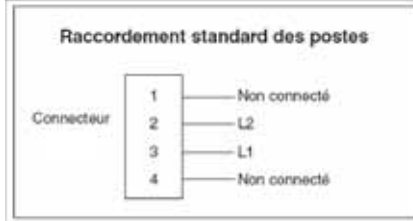

A pair is required to connect the sets. We recommend using a shielded cable that is grounded on the splitter side.

The line is always wired to the 2 middle contacts of the set's RJ11 connector.

If your configuration is different, cords are available to connect the sets to the telephone network:

- Standard wall socket (French type): HK1040B (kit of 10 cords)
- RJ45 wall socket (with 7 and 8 wires): HK1041A (kit of 10 cords)

Note: the distance required is 1000 m in 4/10 and 1800 m in 6/10.

Mounting the telephone

Installation on the desktop

The terminal can be placed on the desktop thanks to two stands fixed under the telephone. Four inclination angles allow you to choose the position of your telephone.

Mount each stand by inserting it in the notches on the telephone base. Three pairs of notches are available in the upper part of the shell. Each stand has two pairs of notches (1 and 2 or 2 and 3) to obtain different inclination angles. The stands may also be reversed to obtain two additional angles.

Use the second and third notches from the top for a higher angle. For a lower angle, use the first and second notches. Then push in the stand until it clicks in.

Installing the terminal

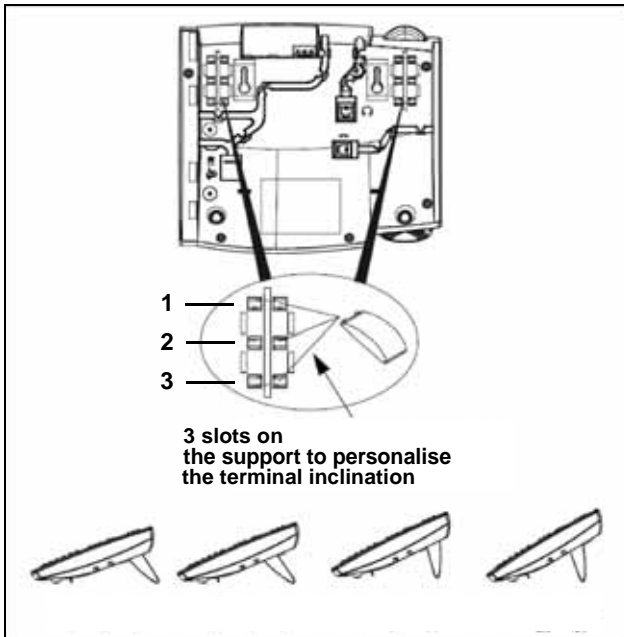

Wall-mounting

Installing the handset attachment system

When wall-mounted, the handset is attached to a lug which should be brought out from the shell:

- 1 - Using a pointed and rigid tool, pull out the lug completely from its slot located where the handset earpiece is placed.
- 2 - Change the direction of the lug and re-insert it in its notch by pressing it. The lug must come out of the notch and allow the handset to be attached.

Fixing the terminal to the wall

The telephone has two pre-drilled holes at the back of the shell. Mark on the wall the drilling locations for the fastening screws. Some plugs will be needed, according to type of wall. The screws and plugs are delivered with the telephone.

Place the telephone's wall-mounting holes above the screw heads on the wall then pull downwards to lock the telephone.

Installing the terminal

Installing module M670 on Astra 6757

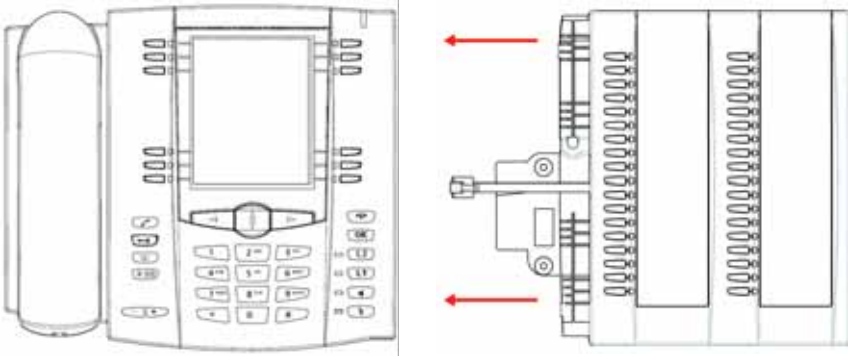

The extension module is used to add 36 additional programmable keys to the terminal. To add the extension module.

- 1 - Turn the telephone and identify the extension module marked .
- 2 - Remove the socket cover.
- 3 - Insert the extension module cable connector in the socket until it locks.
- 4 - Slip the cable of the module into the slot.
- 5 - To fix the extension module to the terminal, connect the fixing points and fix the two items using the screws provided.
- 6 - Place the extension module stand like the terminal stands.

Note: to use the keys on the alphanumeric keypad during call by name, DCF 364 must be declared on 1.



Installing the terminal

Programmable key equivalence

This chapter describes the programmable key equivalence when a previous terminal M7xx is replaced with an Aastra terminal 675x, or when a terminal is replaced with another one.

Aastra terminal 6757		Extension M670 for Aastra 6757			
1 : Key L1		as of R5.1c			
2 : Key L2		prior to R5.1c			
Keys located on the various pages:		23	41	24	23
3	6	24	42	26	25
4	7	25	43	28	27
5	#1	26	44	30	29
		27	45	32	31
8	11	28	46	34	33
9	12	29	47	36	35
10	#2	30	48	38	37
		31	49	40	39
13	16	32	50	42	41
14	17	33	51	44	43
15	#3	34	52	46	45
		35	53	48	47
18	21	36	54	50	49
19	22	37	55	52	51
20	#4	38	56	54	53
		39	57	56	55
		40	58	58	57

Tips and safety

- Caution!** Do not install the device in a damp room or near a water outlet. This device must be used at a temperature between 5°C and 45°C.
- Telephone connection:** This device cannot be connected to the public network. This telephone set is designed to be used with a private switching system from the Aastra ranges. The voltages present on this network are classed TRT1 (Telephone Network Voltage) according to standard EN 60-950.
- Connections** Plug the telephone cable only on the socket meant for this. Do not modify the connectors.
- Maintenance:** First use a cloth moistened with slightly soapy water, then wipe with a dry cloth. Do not use solvents or household cleaning products, so that your set will retain its new look.
- Disposal:**  The disposal of this product is subject to national regulations on the disposal of electrical and electronic equipment.
- CE marking:**  certifies product conformity with applicable standards in accordance with directive R&TTE 1999/5/CE.
- Conformity:** The declaration of conformity is available on: www.aastra.com
- Warning:** This device is a Class A product. In a domestic environment it may cause some radio interference. In this case, the user may be required to take appropriate measures.

AMT/PUD/TR/0062/1/1/EN
09/2009

Aastra 5000 is a registered trademark of Aastra.
Copyright © Aastra

This document is not contractually binding. The information given is for guidance only and may be modified without prior notice. Reproduction forbidden.

AASTRA

1 rue Arnold Schoenberg
Rond-point des Saules
78286 Guyancourt Cedex - France
Tel.: + 33 (0)1 30 96 42 00
Fax: + 33 (0)1 30 96 43 00
www.aastra.com